

## FEATURES

- **Guaranteed 0.4% Initial Voltage Tolerance**
- **0.1Ω Typical Dynamic Output Impedance**
- Fast Turn On
- Sink Current Capability, 1mA to 100mA
- Low Reference Pin Current
- Available in N8, S8 or 3-Lead TO-92 Z Packages

## APPLICATIONS

- Linear Regulators
- Adjustable Power Supplies
- Switching Power Supplies

## DESCRIPTION

The LT<sup>®</sup>1431 is an adjustable shunt voltage regulator with 100mA sink capability, 0.4% initial reference voltage tolerance and 0.3% typical temperature stability. On-chip divider resistors allow the LT1431 to be configured as a 5V shunt regulator, with 1% initial voltage tolerance and requiring no additional external components. By adding two external resistors, the output voltage may be set to any value between 2.5V and 36V. The nominal internal current limit of 100mA may be decreased by including one external resistor.

A simplified 3-pin version, the LT1431CZ/LT1431IZ, is available for applications as an adjustable reference and is pin compatible with the TL431.

LT, LTC and LT are registered trademarks of Linear Technology Corporation.

## TYPICAL APPLICATION

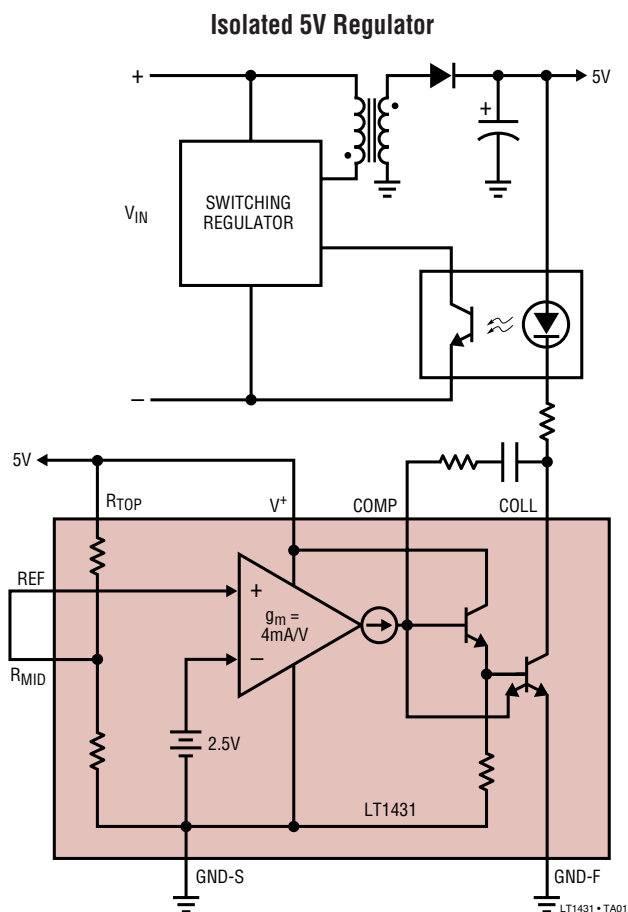

**$V_{REF}$  vs Temperature**

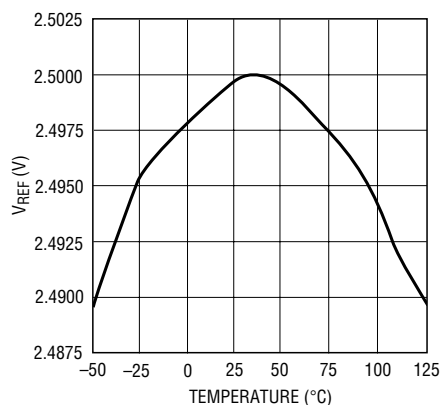

LT1431 • TA01b

# LT1431

## ABSOLUTE MAXIMUM RATINGS (Note 1)

$V^+$ , $V_{\text{COLLECTOR}}$ .....	36V	Junction Temperature Range	
$V_{\text{COMP}}$ , $R_{\text{TOP}}$ , $R_{\text{MID}}$ , $V_{\text{REF}}$ .....	6V	LT1431M (OBSOLETE) .....	-55°C to 150°C
GND-F to GND-S .....	0.7V	LT1431I .....	-40°C to 100°C
Ambient Temperature Range		LT1431C .....	0°C to 100°C
LT1431M (OBSOLETE) .....	-55°C to 125°C	Storage Temperature Range .....	-65°C to 150°C
LT1431I .....	-40°C to 85°C	Lead Temperature (Soldering, 10 sec).....	300°C
LT1431C .....	0°C TO 70°C		

## PACKAGE/ORDER INFORMATION

<p>TOP VIEW</p> <p>N8 PACKAGE 8-LEAD PDIP S8 PACKAGE 8-LEAD PLASTIC SO</p> <p><math>T_J \text{ MAX} = 100^\circ\text{C}</math>, <math>\theta_{JA} = 130^\circ\text{C/W}</math> (N) <math>T_J \text{ MAX} = 100^\circ\text{C}</math>, <math>\theta_{JA} = 170^\circ\text{C/W}</math> (S)</p> <p><math>T_J \text{ MAX} = 150^\circ\text{C}</math>, <math>\theta_{JA} = 100^\circ\text{C/W}</math> (J)</p> <p><b>OBSOLETE PACKAGE</b> Consider the N8 or S8 for Alternate Source</p>	ORDER PART NUMBER	<p>BOTTOM VIEW</p> <p>Z PACKAGE 3-LEAD TO-92 PLASTIC <math>T_J \text{ MAX} = 100^\circ\text{C}</math>, <math>\theta_{JA} = 150^\circ\text{C/W}</math></p>	ORDER PART NUMBER
	LT1431CN8		LT1431CZ
	LT1431IN8		LT1431IZ
	LT1431CS8		
	S8 PART MARKING		
	1431		
	1431I		
	LT1431MJ8		

Consult LTC Marketing for parts specified with wider operating temperature ranges.

## ELECTRICAL CHARACTERISTICS

The ● denotes the specifications which apply over the full operating temperature range, otherwise specifications are at  $T_A = 25^\circ\text{C}$ .  $I_K = 10\text{mA}$  unless otherwise specified (Note 2)

SYMBOL	PARAMETER	CONDITIONS	LT1431M/I			LT1431C			UNITS	
			MIN	TYP	MAX	MIN	TYP	MAX		
$V_{\text{REF}}$	Reference Voltage	$V_{KA} = 5\text{V}$ , $I_K = 2\text{mA}$ , (Note 3)	● 2.490	2.500	2.510	2.490	2.500	2.510	V	
			2.465		2.535	2.480		2.520	V	
$\Delta V_{\text{REF}}/\Delta T$	Reference Drift	$V_{KA} = 5\text{V}$ , $I_K = 2\text{mA}$	●	50		30			ppm/°C	
$\Delta V_{\text{REF}}/\Delta V_{KA}$	Voltage Ratio, Reference to Cathode (Open-Loop Gain)	$I_K = 2\text{mA}$ , $V_{KA} = 3\text{V}$ to $36\text{V}$	●	0.2	0.5	0.2	0.5		mV/V	
$ I_{\text{REF}} $	Reference Input Current	$V_{KA} = 5\text{V}$ , $T_A = 25^\circ\text{C}$	●	0.2	1.0	0.2	1.0		$\mu\text{A}$	
					1.5		1.2		$\mu\text{A}$	
$I_{\text{MIN}}$	Minimum Operating Current	$V_{KA} = V_{\text{REF}}$ to $36\text{V}$		0.6	1.0	0.6	1.0		mA	
$ I_{\text{OFF}} $	Off-State Cathode Current	$V_{KA} = 36\text{V}$ , $V_{\text{REF}} = 0\text{V}$	●		1	1			$\mu\text{A}$	
					15		2		$\mu\text{A}$	
$ I_{\text{LEAK}} $	Off-State Collector Leakage Current	$V_{\text{COLL}} = 36\text{V}$ , $V^+ = 5\text{V}$ , $V_{\text{REF}} = 2.4\text{V}$	●		1	1			$\mu\text{A}$	
					5		2		$\mu\text{A}$	
$ Z_{KA} $	Dynamic Impedance	$V_{KA} = V_{\text{REF}}$ , $I_K = 1\text{mA}$ to $100\text{mA}$ , $f \leq 1\text{kHz}$			0.2		0.2		$\Omega$	
$I_{\text{LIM}}$	Collector Current Limit	$V_{KA} = V_{\text{REF}} + 50\text{mV}$	●	80	360	100	260		mA	
	5V Reference Output	Internal Divider Used, $I_K = 2\text{mA}$		4.950	5.000	5.050	4.950	5.000	5.050	V

1413fc

# ELECTRICAL CHARACTERISTICS

**Note 1:** Absolute Maximum Ratings are those values beyond which the life of a device may be impaired.

**Note 2:**  $V_{KA}$  is the cathode voltage of the LT1431CZ/IZ and corresponds to  $V^+$  of the LT1431CN8/IN8/CS8/IS8.  $I_K$  is the cathode current of the LT1431CZ/IZ and corresponds to  $I(V^+) + I_{COLLECTOR}$  of the LT1431CN8/IN8/CS8/IS8.

**Note 3:** The LT1431 has bias current cancellation which is effective only for  $V_{KA} \geq 3V$ . A slight ( $\approx 2mV$ ) shift in reference voltage occurs when  $V_{KA}$  drops below 3V. For this reason, these tests are not performed at  $V_{KA} = V_{REF}$ .

# TYPICAL PERFORMANCE CHARACTERISTICS

2.5V Reference  $I_K$  vs  $V_{KA}$

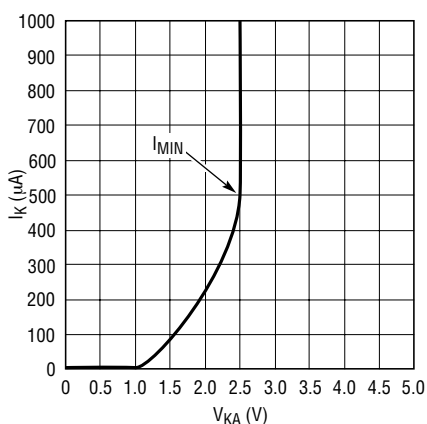

LT1431 • TPC01

$V_{REF}$  and  $I_{REF}$  vs  $V^+$

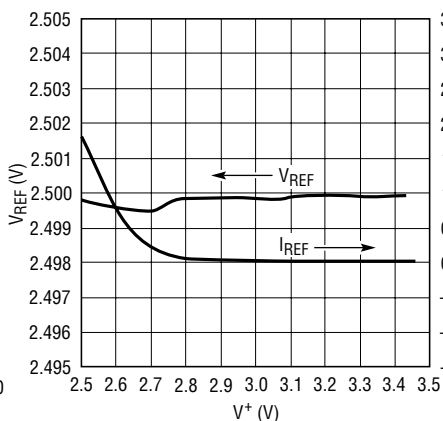

LT1431 • TPC02

$V_{REF}$  and  $I_{REF}$  vs  $V^+$

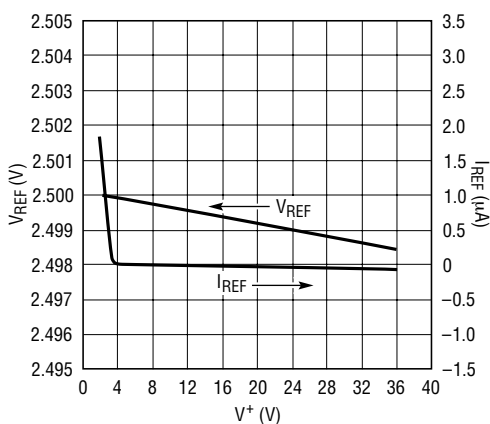

LT1431 • TPC03

$V_{REF}$  and  $I_{REF}$  vs Temperature

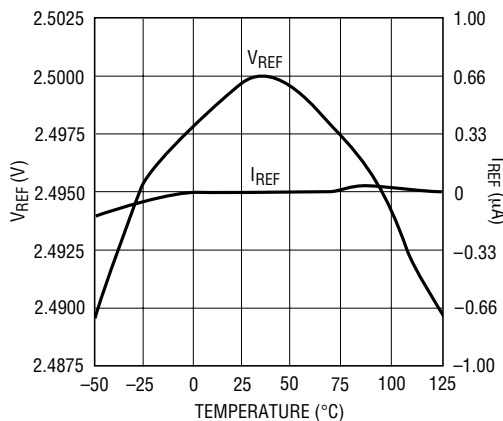

LT1431 • TPC04

$I_{LIMIT}$  vs Temperature with External Resistor

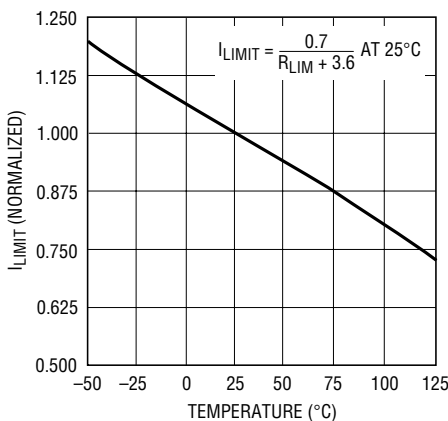

LT1431 • TPC05

COLLECTOR  $V_{SAT}$  vs Temperature vs Current

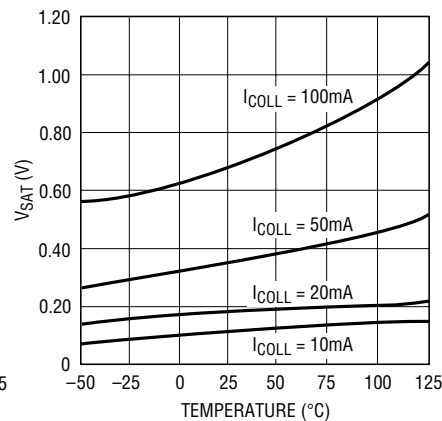

LT1431 • TPC06

# TYPICAL PERFORMANCE CHARACTERISTICS

Propagation Delay vs Overdrive

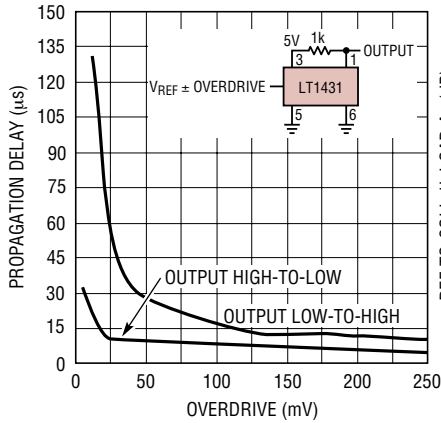

LT1431 • TPC07

Voltage Gain and Phase vs Frequency

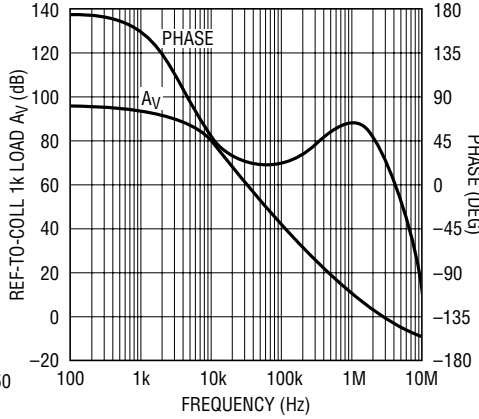

LT1431 • TPC08

Transconductance and Phase vs Frequency (REF to COLL)

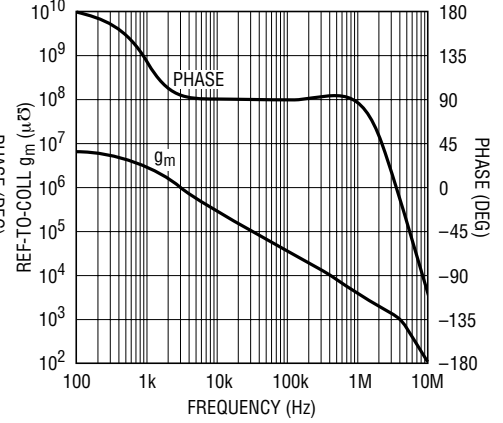

LT1431 • TPC09

Transconductance and Phase vs Frequency (Ref to Comp)

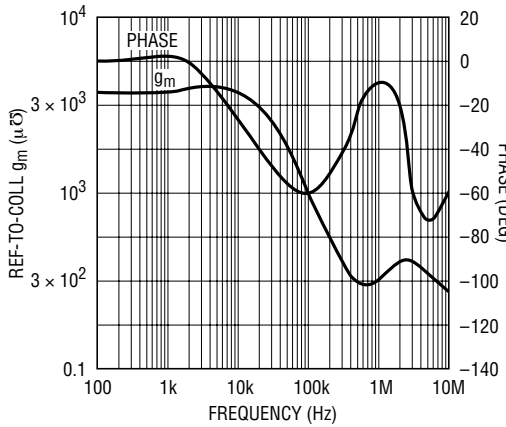

LT1431 • TPC10

Dynamic Impedance vs Frequency

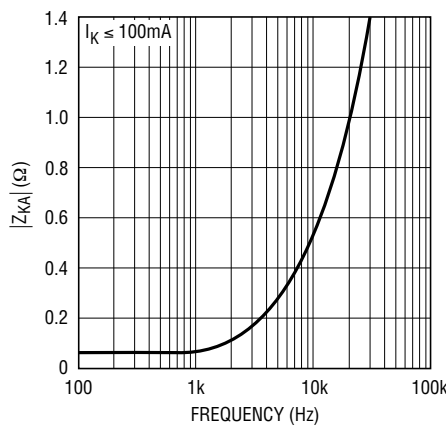

LT1431 • TPC11

VCOMP vs Temperature vs ICOLL

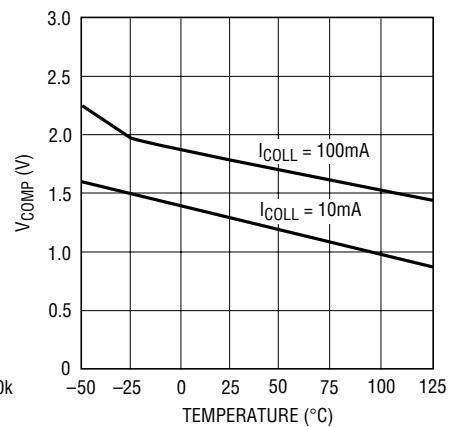

LT1431 • TPC12

ICOMP vs VCOMP vs VREF

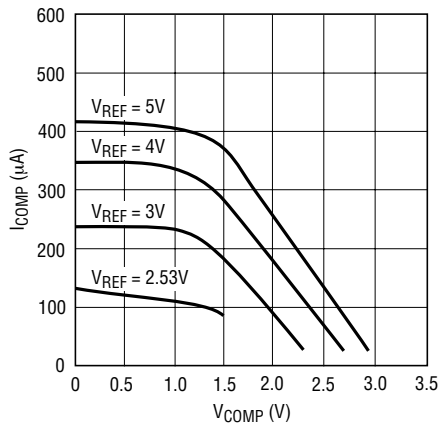

LT1431 • TPC13

Noise vs Frequency

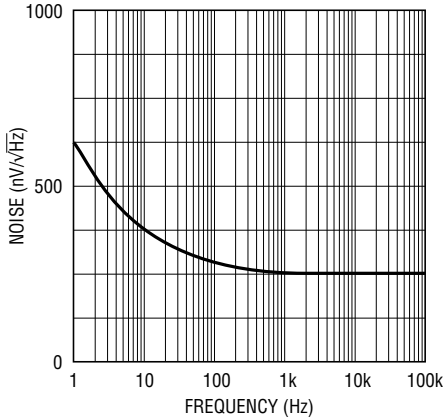

LT1431 • G14

0.1Hz to 10Hz Noise

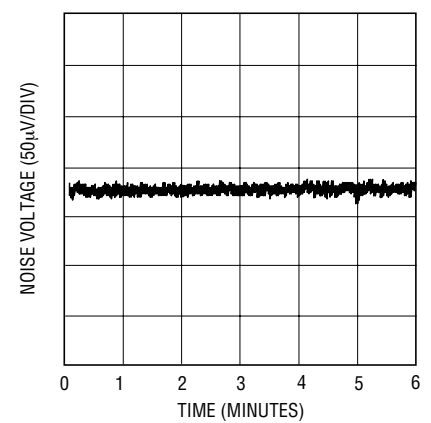

LT1431 • TPC15

## PIN FUNCTIONS

**COLL (Pin 1):** Open collector of the output transistor. The maximum pin voltage is 36V. The saturation voltage at 100mA is approximately 1V.

**COMP (Pin 2):** Base of the driver for the output transistor. This pin allows additional compensation for complex feedback systems and shutdown of the regulator. It must be left open if unused.

**V<sup>+</sup> (Pin 3):** Bias voltage for the entire shunt regulator. The maximum input voltage is 36V and the minimum to operate is equal to  $V_{REF}$  (2.5V). The quiescent current is typically 0.6mA.

**R<sub>TOP</sub> (Pin 4):** Top of the on-chip 5k-5k resistive divider that guarantees 1% accuracy of operation as a 5V shunt regulator with no external trim. The pin is tied to COLL for self-contained 5V operation. It may be left open if unused. See note on parasitic diodes below.

**GND-S (Pin 5):** Ground reference for the on-chip resistive divider and shunt regulator circuitry except for the output transistor. This pin allows external current limit of the output transistor with one resistor between GND-F (force) and GND-S (sense).

**GND-F (Pin 6):** Emitter of the output transistor and substrate connection for the die.

**R<sub>MID</sub> (Pin 7):** Middle of the on-chip resistive divider string between R<sub>TOP</sub> and GND-S. The pin is tied to REF for self-contained 5V operation. It may be left open if unused.

**REF (Pin 8):** Control pin of the shunt regulator with a 2.5V threshold. If  $V^+ > 3V$ , input bias current cancellation reduces  $I_B$  to 0.2 $\mu$ A typical.

COMP, R<sub>TOP</sub>, R<sub>MID</sub>, and REF have static discharge protection circuits that must not be activated on a continuous basis. Therefore, the absolute maximum DC voltage on these pins is 6V, well beyond the normal operating conditions.

As with all bipolar ICs, the LT1431 contains parasitic diodes which must not be forward biased or else anomalous behavior will result. Pin conditions to be avoided are R<sub>TOP</sub> below R<sub>MID</sub> in voltage and any pin below GND-F in voltage (except for GND-S).

The following pin definitions apply to the Z package.

**CATHODE:** Corresponds to COLL and V<sup>+</sup> tied together.

**ANODE:** Corresponds to GND-S and GND-F tied together.

**REF:** Corresponds to REF.

## BLOCK DIAGRAM

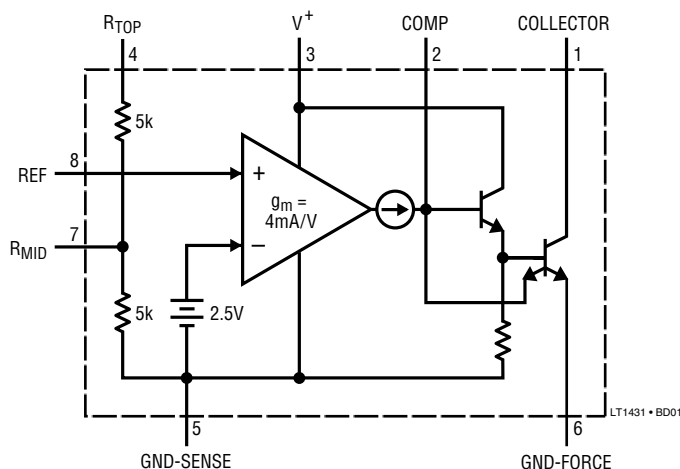

## APPLICATIONS INFORMATION

### Frequency Compensation

As a shunt regulator, the LT1431 is stable for all capacitive loads on the COLL pin. Capacitive loading between 0.01 $\mu$ F and 18 $\mu$ F causes reduced phase margin with some ringing under transient conditions. Output capacitors should not be used arbitrarily because output noise is not necessarily reduced.

Excess capacitance on the REF pin can introduce enough phase shift to induce oscillation when configured as a reference >2.5V. This can be compensated with capacitance between COLL and REF (phase lead). More complicated feedback loops may require shaping of the frequency

response of the LT1431 with dominant pole or pole-zero compensation. This can be accomplished with a capacitor or series resistor and capacitor between COLL and COMP.

The compensation schemes mentioned above use voltage feedback to stabilize the circuits. There must be voltage gain at the COLL pin for them to be effective, so the COLL pin must see a reasonable AC impedance. Capacitive loading of the COLL pin reduces the AC impedance, voltage gain, and frequency response, thereby decreasing the effectiveness of the compensation schemes, but also decreasing their necessity.

## TYPICAL APPLICATIONS

2.5V Reference  
3-Pin Package

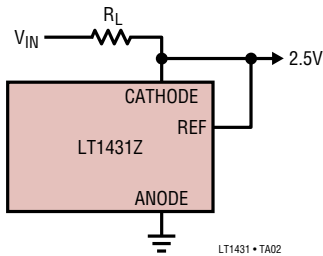

2.5V Reference  
8-Pin Package

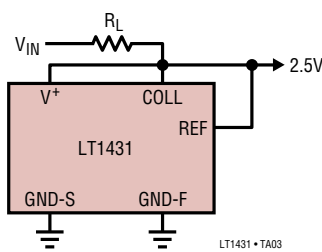

5V Reference

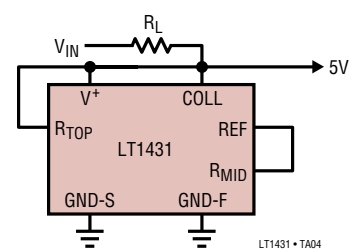

Increasing 5V Reference

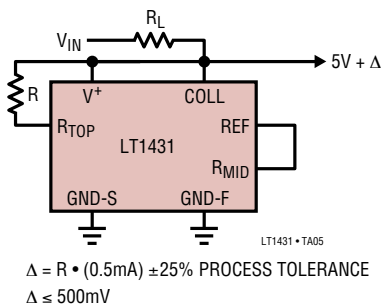

Programmable Reference with Adjustable  
Current Limit

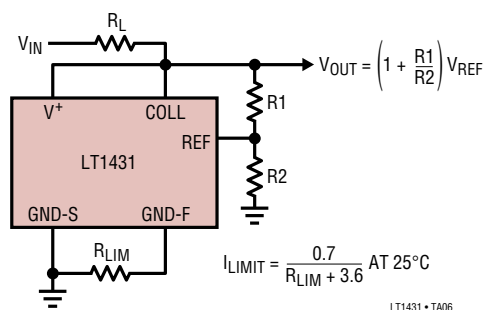

# TYPICAL APPLICATIONS

## PNP Low Dropout 5V Regulator\*

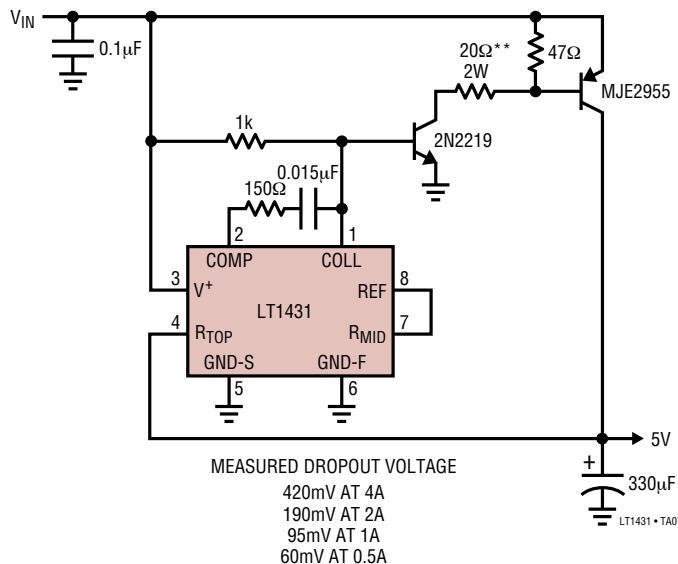

\*NO SHORT-CIRCUIT PROTECTION  
 \*\*MAY BE INCREASED AT LOWER WATTAGE  
 FOR LOWER OUTPUT CURRENTS

## FET Low Dropout 5V Regulator with Current Limit

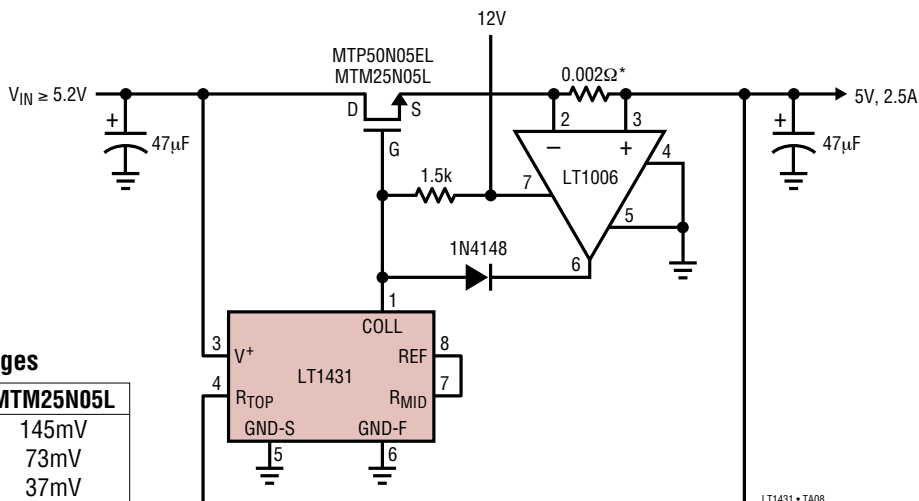

### Measured Dropout Voltages

I <sub>LOAD</sub>	MTP50N05EL	MTM25N05L
2A	47mV	145mV
1A	22mV	73mV
0.5A	11.5mV	37mV

\*1.5" #23 SOLID COPPER WIRE  
 ~0.002Ω → 3A LIMIT

# TYPICAL APPLICATIONS

12V to 5V Buck Converter with Foldback Current Limit\*

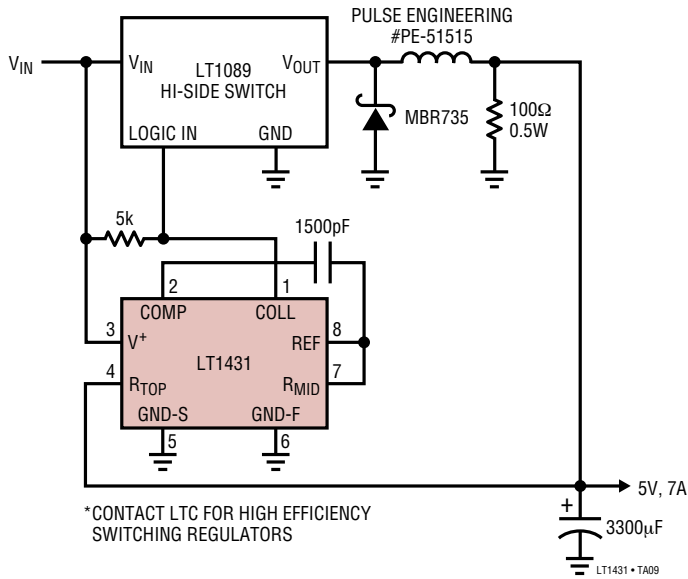

Buck Converter Efficiency

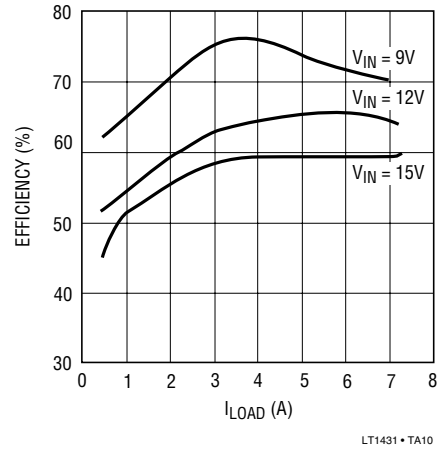

Isolated 5V to ±15V Flyback Converter

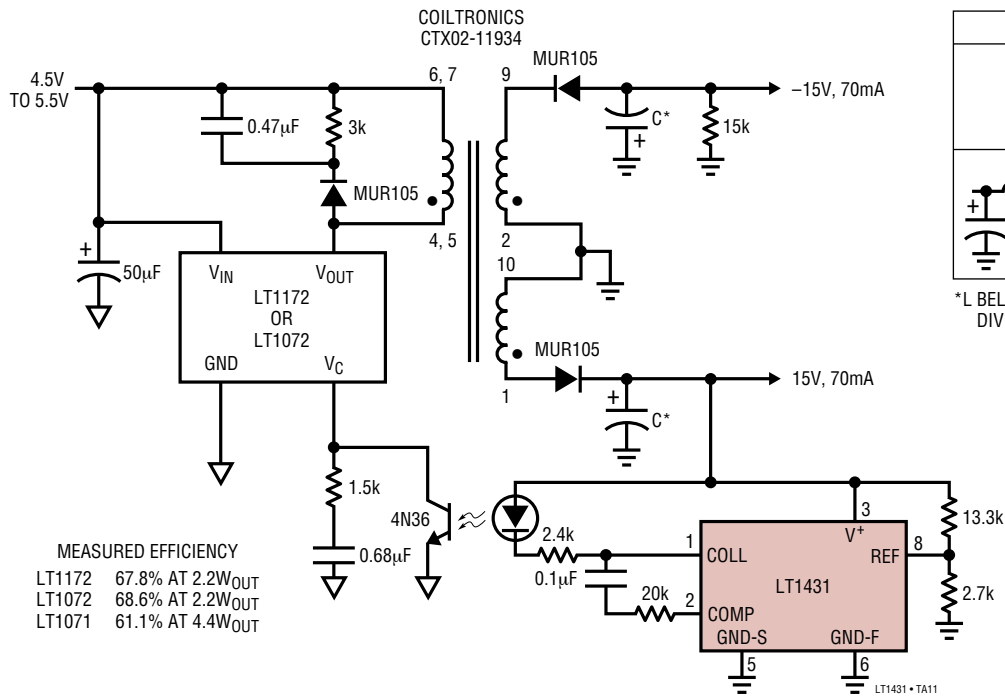

Fully Loaded Output Ripple vs Filtering

Filtering	LT1172	LT1072
C*	30mV <sub>P-P</sub>	40mV <sub>P-P</sub>
L*	6mV <sub>P-P</sub>	8mV <sub>P-P</sub>

\*L BELL INDUSTRIES J.W. MILLER DIVISION 9310-36 10μH, 450mA



# TYPICAL APPLICATIONS

**5V Power Supply Monitor with ±500mV Window and 50mV Hysteresis**

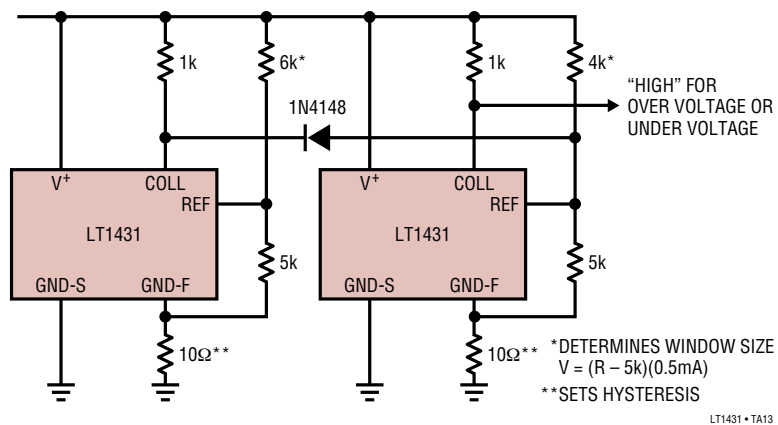

**Transfer Function**

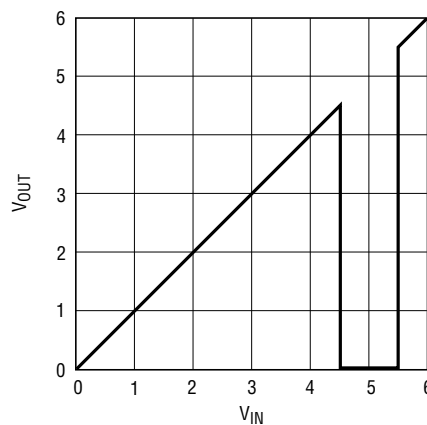

**High Efficiency Buck Converter E = 85% to 89%**

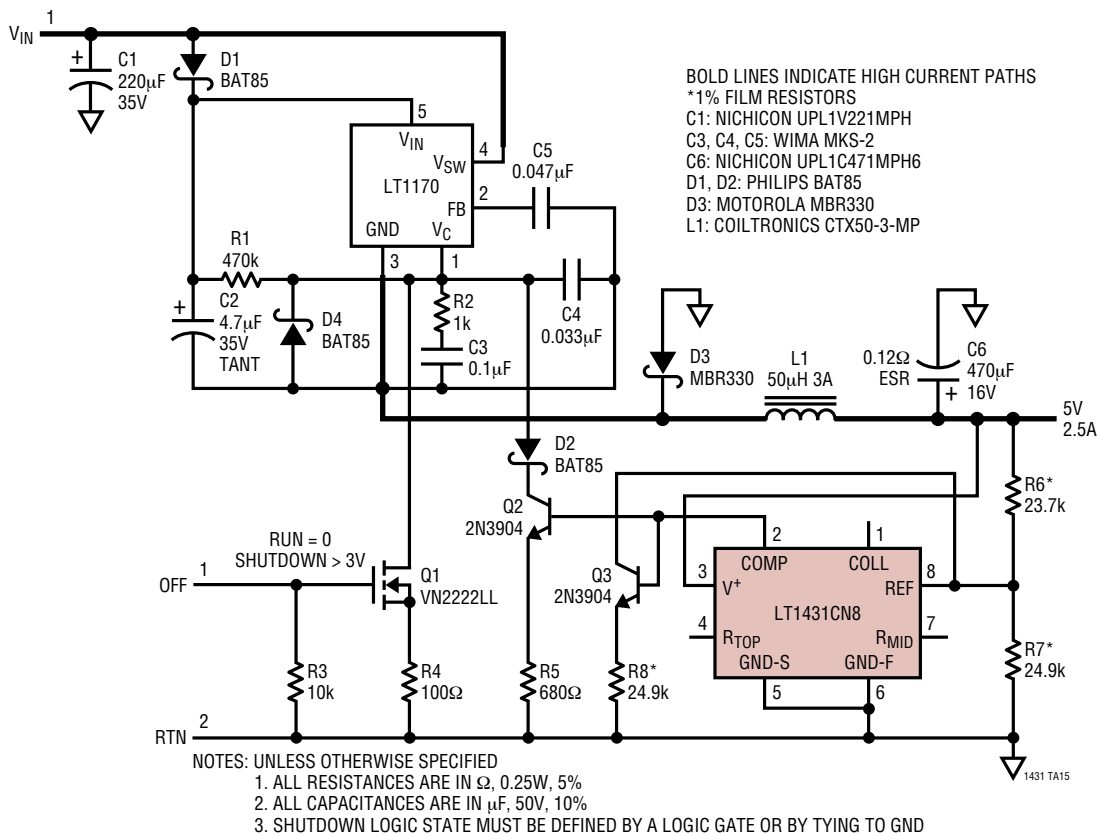

# SCHEMATIC DIAGRAM

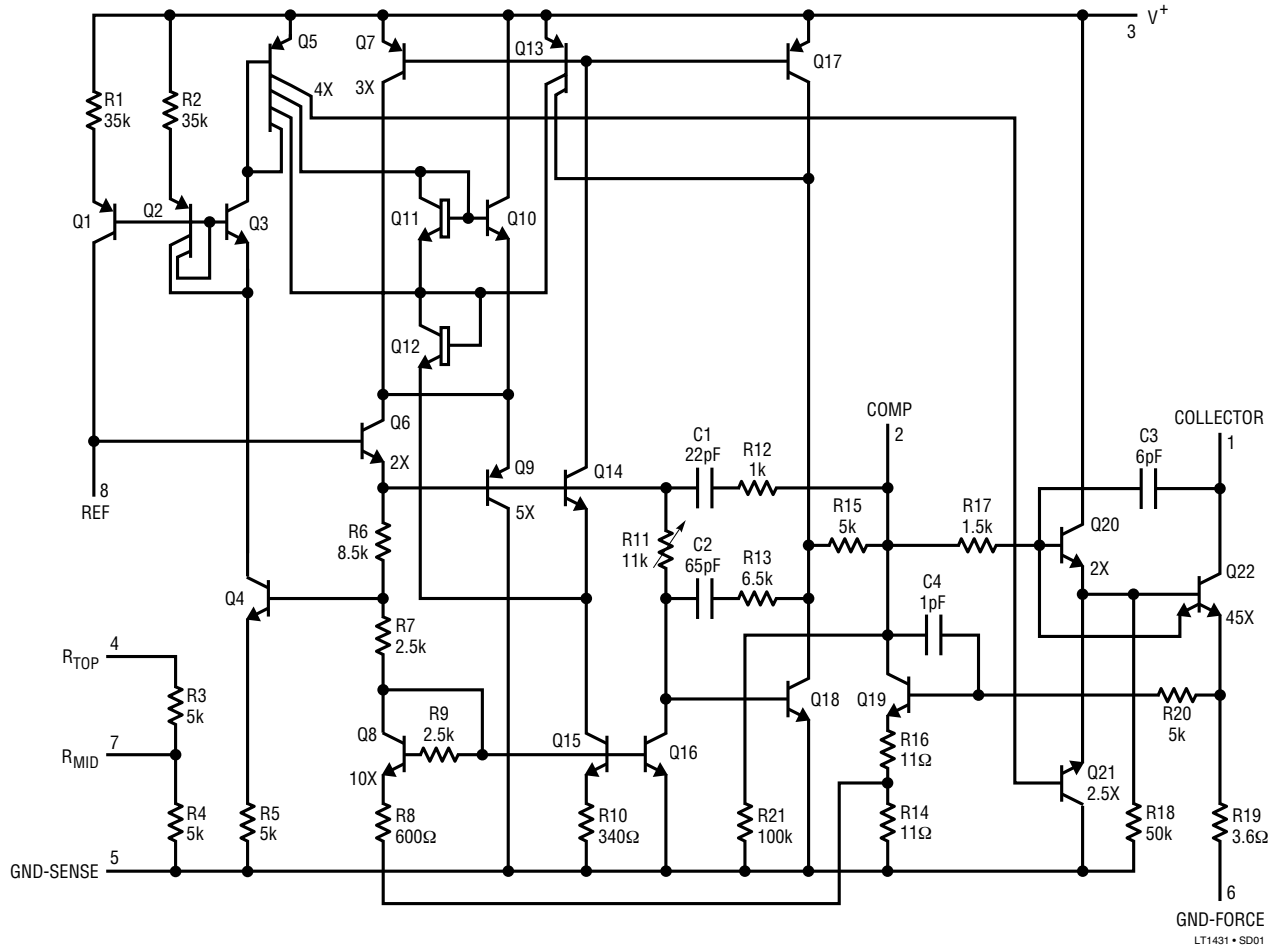

# PACKAGE DESCRIPTION

**J8 Package**  
**8-Lead CERDIP (Narrow .300 Inch, Hermetic)**  
 (Reference LTC DWG # 05-08-1110)

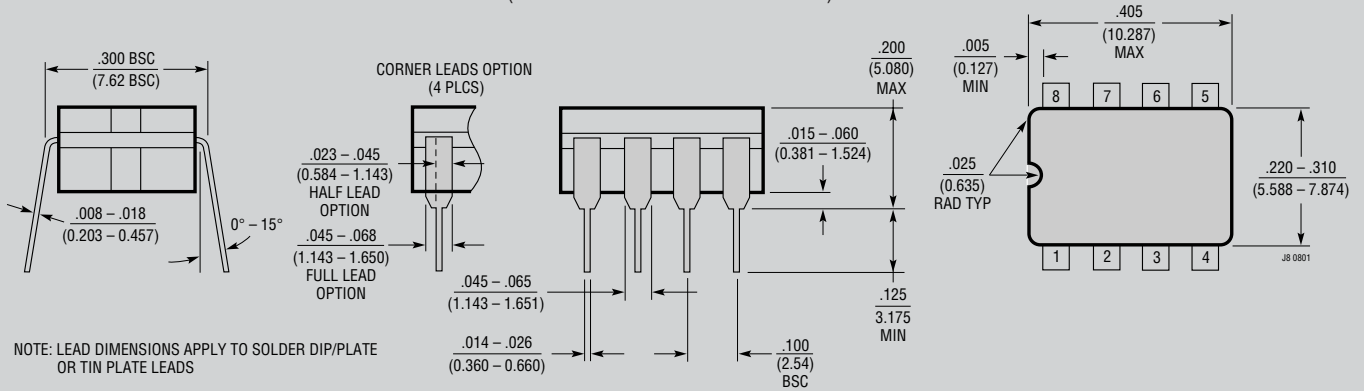

**OBSOLETE PACKAGE**

# PACKAGE DESCRIPTION

## N8 Package 8-Lead PDIP (Narrow .300 Inch) (Reference LTC DWG # 05-08-1510)

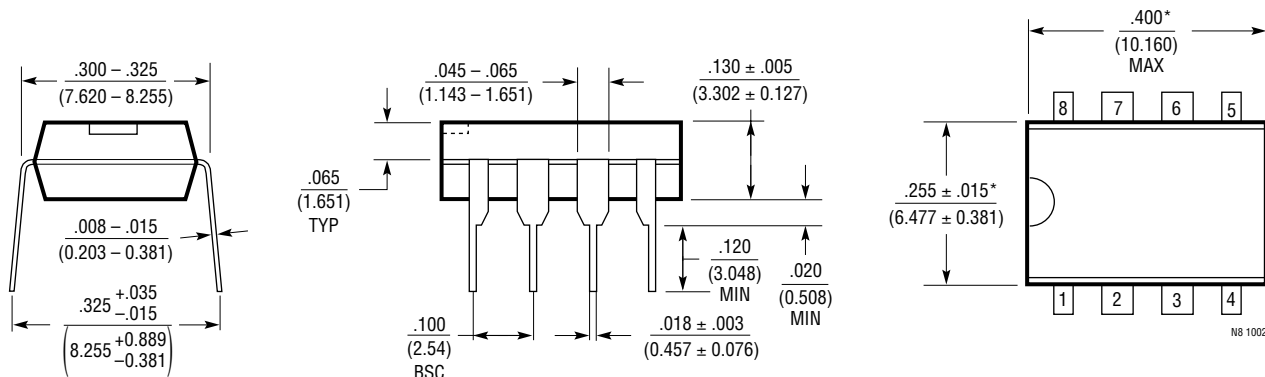

NOTE:  
1. DIMENSIONS ARE  $\frac{\text{INCHES}}{\text{MILLIMETERS}}$   
\*THESE DIMENSIONS DO NOT INCLUDE MOLD FLASH OR PROTRUSIONS.  
MOLD FLASH OR PROTRUSIONS SHALL NOT EXCEED .010 INCH (0.254mm)

## S8 Package 8-Lead Plastic Small Outline (Narrow .150 Inch) (Reference LTC DWG # 05-08-1610)

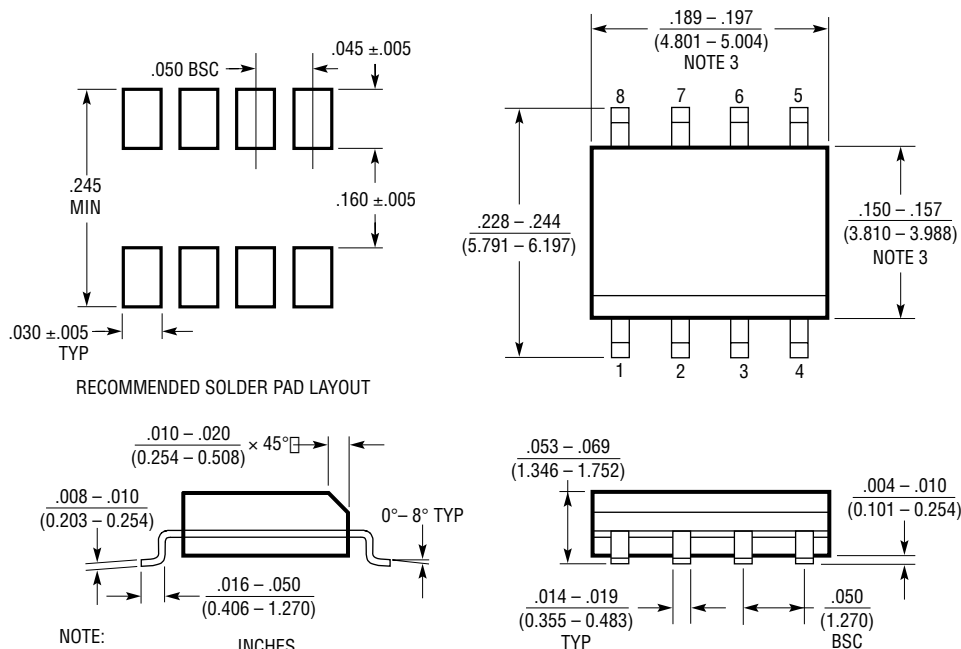

NOTE:  
1. DIMENSIONS IN  $\frac{\text{INCHES}}{\text{MILLIMETERS}}$   
2. DRAWING NOT TO SCALE  
3. THESE DIMENSIONS DO NOT INCLUDE MOLD FLASH OR PROTRUSIONS.  
MOLD FLASH OR PROTRUSIONS SHALL NOT EXCEED .006" (0.15mm)

S08 0303

**PACKAGE DESCRIPTION**

**Z Package**  
**3-Lead Plastic TO-92 (Similar to TO-226)**  
 (Reference LTC DWG # 05-08-1410)

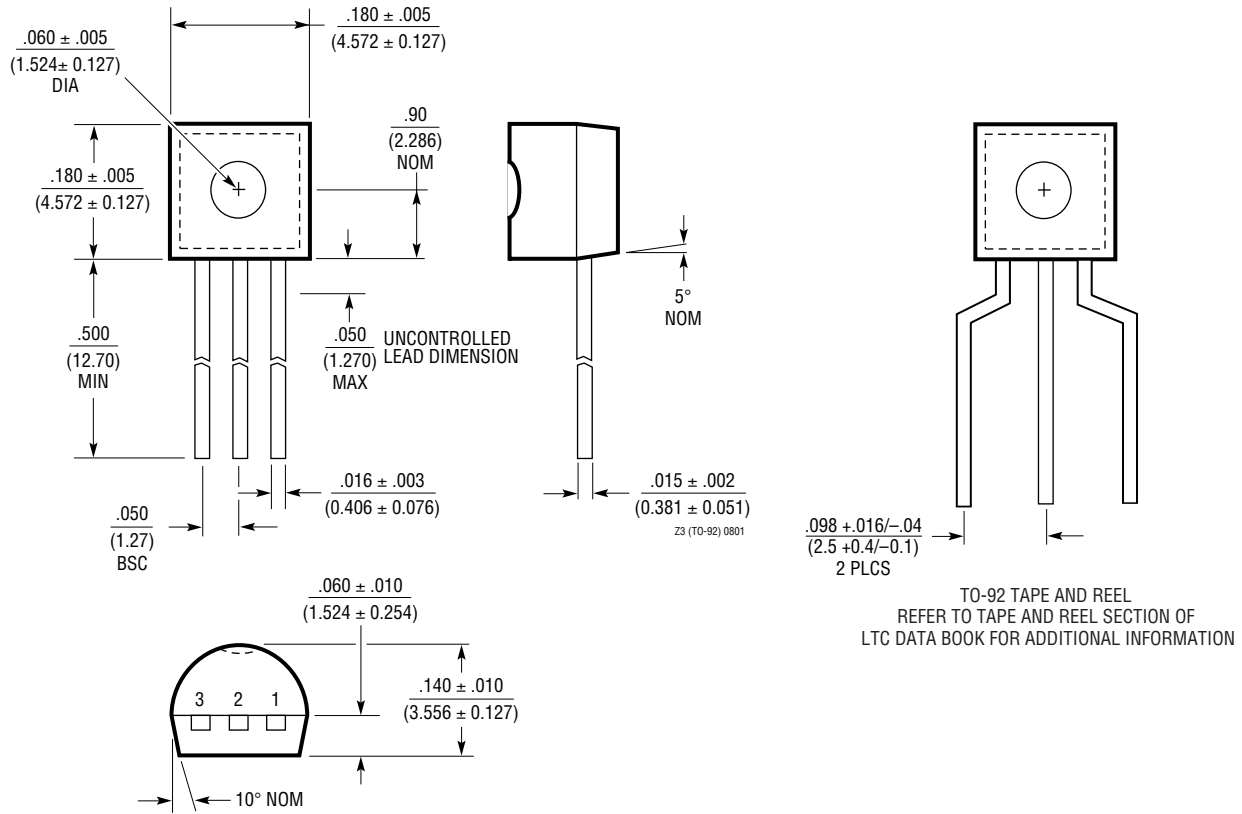

**RELATED PARTS**

PART NUMBER	DESCRIPTION	COMMENTS
LTC <sup>®</sup> 3722	Synchronous Full-Bridge Controller	Zero Voltage Switching, Adjustable 2V <sub>S</sub> Timing
LTC3723	Synchronous Push-Pull PWM Controller	1.5A Sink, 1A Source Output Drivers, Adjustable Dead Time
LTC3803	SOT-23 Flyback Controller	Adjustable Slope Compensation, 200kHz Operation
LTC3806	Synchronous Flyback Controller	Excellent Cross Regulation, High Efficiency
LTC3900/LTC3901	Synchronous Rectifiers for Forward and Push-Pull Converters	Programmable Time Out, Reverse Inductor Current Sense
LT4430	Optocoupler Driver in SOT-23	Overshoot Control, 600mV Reference, High Bandwidth Error Amplifier